

DATA FILE

LATERAL LOAD CONNECTIONS FOR LOW-SLOPE ROOF DIAPHRAGMS



WOOD

The Miracle Material™



Wood is the right choice for a host of construction applications. It is the earth's natural, energy efficient and renewable building material.

Engineered wood is a better use of wood. The miracle in today's wood products is that they make more efficient use of the wood fiber resource to make stronger plywood, oriented strand board, I-joists, glued laminated timbers, and laminated veneer lumber. That's good for the environment, and good for designers seeking strong, efficient, and striking building design.

A few facts about wood.

▪ **We're not running out of trees.** One-third of the United States land base – 731 million acres – is covered by forests. About two-thirds of that 731 million acres is suitable for repeated planting and harvesting of timber. But only about half of the land suitable for growing timber is open to logging.



Most of that harvestable acreage also is open to other uses, such as camping, hiking, and hunting. Forests fully cover one-half of Canada's land mass. Of this forestland, nearly half is considered productive, or capable of producing timber on a sustained yield basis. Canada has the highest per capita accumulation of protected natural areas in the world – areas including national and provincial parks.



▪ **We're growing more wood every day.** American landowners plant more than two billion trees every year. In addition, millions of trees seed naturally. The forest products industry, which comprises about 15 percent of forestland ownership, is responsible for 41 percent of replanted forest acreage. That works out to more than one billion trees a year, or about three million trees planted every day. This high rate of replanting accounts for the fact that each year, 27 percent more timber is grown than is harvested. Canada's replanting record shows a fourfold increase in the number of trees planted between 1975 and 1990.

▪ **Manufacturing wood is energy efficient.** Wood products made up 47 percent of all industrial raw materials manufactured in the United States, yet consumed only 4 percent of the energy needed to manufacture all industrial raw materials, according to a 1987 study.

Material	Percent of Production	Percent of Energy Use
Wood	47	4
Steel	23	48
Aluminum	2	8



▪ **Good news for a healthy planet.** For every ton of wood grown, a young forest produces 1.07 tons of oxygen and absorbs 1.47 tons of carbon dioxide.

Wood, the miracle material for the environment, for design, and for strong, lasting construction.



NOTICE:
The recommendations in this guide apply only to panels that bear the APA trademark. Only panels bearing the APA trademark are subject to the Association's quality auditing program.

Introduction

For many years the wood roof was the preferred system for structures both large and small. Its availability, ease of construction, and economy made wood the roof material of choice for most large commercial structures. Throughout the last 20 years or so, ever increasing code mandates in the area of seismic design and detailing have slowly increased the demands on wood-framed roof systems in the commercial low-slope roof market.

Recently, engineers and connection fabricators have developed a number of new techniques and products to more efficiently and economically make code-required connections and increase the viability of wood roof systems in high wind and seismic regions of the country. These same connection types ensure short construction times and provide large, flat wood roof systems with even greater economies. These innovations, including the use of the popular panelized roof

system along with new connection details and design techniques, are making wood roofs more lateral-load resistant and economical than ever.

Panelized Roof Systems

Panelized, sometimes referred to as pre-framed roof systems, can save time and labor in commercial structures, while delivering the diaphragm strength to resist lateral loads from high winds or earthquakes. Pre-framed panels are fabricated by using production-line techniques to fasten sections of APA panels to lumber stiffeners. Figure 1 illustrates a typical pre-framed roof-panel section. Assembly can be done at the site or in a shop. No elaborate fabrication equipment is needed. Panel connections are simply nailed.

A roof panel width of 8 feet is usually the most practical with pre-framed panelized construction. The framing members oriented this direction are called stiffeners or subpurlins and provide support for the wood structural panel roof sheathing. Roof sheathing consists of 4 x 8-foot APA

panels with stiffeners pre-framed at 16 or 24 inches on center. The long dimension of the panel typically is oriented parallel to the supports. Because all adjacent panel edges occur over, and are nailed to common framing members, the roof forms a *blocked* diaphragm, thus providing significantly greater seismic and high wind resistance than conventionally framed roofs with unblocked sheathing.

These pre-framed roof panel sections can be fabricated as long as 60 feet; however 48 feet is a more typical length. The panels normally have the purlin attached to one edge of the assembly. Pre-framed panels are lifted into place with a forklift, set on the girders and attached to the adjacent roof section. The ability to place and attach roughly 400 square feet of roofing in a single lift with a minimal on-site construction crew dramatically shortens construction time and makes these roofs an economical alternative to all steel systems.

FIGURE 1

TYPICAL PRE-FRAMED/PANELIZED ROOF PANEL

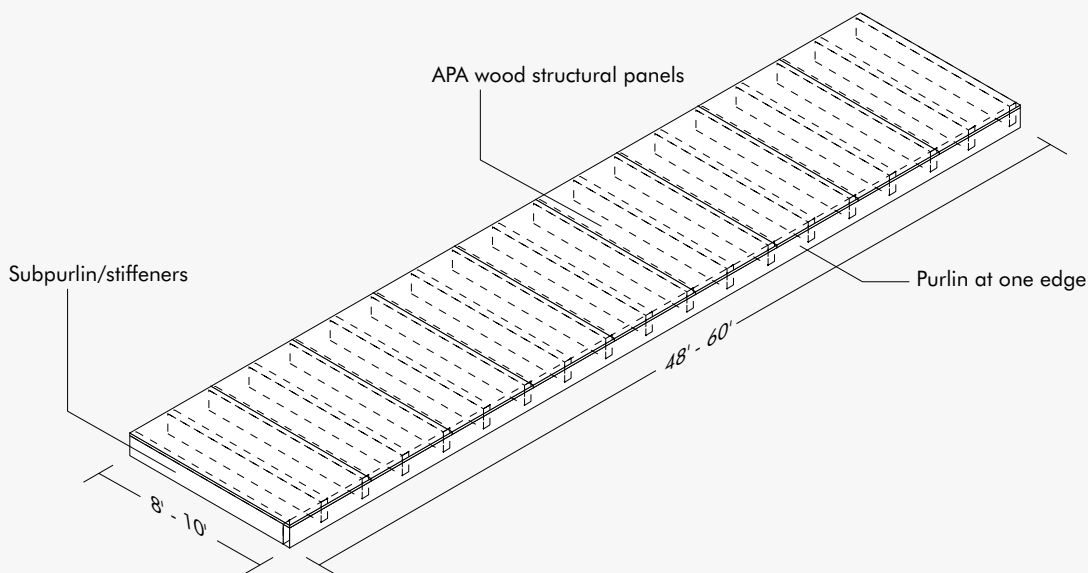

Lateral Connection Details

To assure adequate performance during seismic or high wind events, the roof framing attachment system must be detailed to prevent the introduction of earthquake/wind-induced loads into roof diaphragm sheathing connections that are not designed to withstand such loads. The roof diaphragm is designed to transfer shear forces from the loaded side of the building into the shearwalls running parallel to direction of the load. The roof diaphragm is NOT designed to resist the lateral forces generated in the building that act to pull opposite walls away from each other.

Due to failures of some roof diaphragms during the San Fernando earthquake of 1971, a number of code changes were introduced to the Uniform Building Code that required continuous crossties – tension ties that connect opposite diaphragm chords. These and other code changes requiring increased levels of attachment of concrete and masonry walls to wood diaphragms were adopted to improve the seismic performance of large flat-roofed structures using wood structural panel diaphragms.

One of the purposes of this Data File is to acquaint the owner, designer and contractor with the types of connectors that can be used to meet code requirements for wind or seismic lateral forces. Examples of these details can be seen later in this publication.

Design Techniques

Also covered is the subdiaphragm (also known as the mini-diaphragm) concept that is used to reduce the economic impact of the code-required crossties and make the relevant roof structures considerably easier to construct. This discussion, along with a design example, can be found in Appendix A.

Figure 2 shows an example of a typical roof framing layout in a panelized roof system. In this figure, elements of the roof framing system that carry the seismic loads other than those carried by the diaphragm sheathing are identified and shown later in the detail drawings.

Figures 3 and 4 illustrate the same roof system as shown in Figure 2. In these figures the wall-attachment continuity load path is illustrated for the East-West and North-South directions respectively. A different method of transferring the code-required tension/compression forces was used in each direction to optimize the cost of transferring these forces.

In the East-West direction, the International Building Code and the Uniform Building Code essentially require the use of over 700 individual continuity ties or crossties if placed at 4' on center (each subpurlin attached to its adjoining subpurlins along subpurlin lines at 4' on center). Through the use of subdiaphragms, only 220 connections are required.

In the North-South direction, the purlins are spaced at 8' on center and there are only 2 joints/discontinuities along each purlin line. In the North-South direction, the code-specified continuity ties are required at only 46 locations. In addition, the required ties are relatively low in capacity, and easy and economical to install.

The roof-framing plan also does not provide any large girders acting in the North-South direction that could carry the loads required of a cross-tie. The use of subdiaphragms in this direction could have reduced the number of connections but due to the increased framing complexity and larger capacity of the resulting ties, it was judged not to be cost effective. If additional bays were added to the building along the North-South direction, the use of subdiaphragms might become an economical solution.

Not every possible lateral attachment detail is shown on the following pages. The details illustrated are indicative of the types of connection hardware that can be used in this kind of roof system. In addition to the physical aspects of the details, a range of typical lateral load capacities that can be expected is shown for such applications.

FIGURE 2

PANELIZED ROOF FRAMING

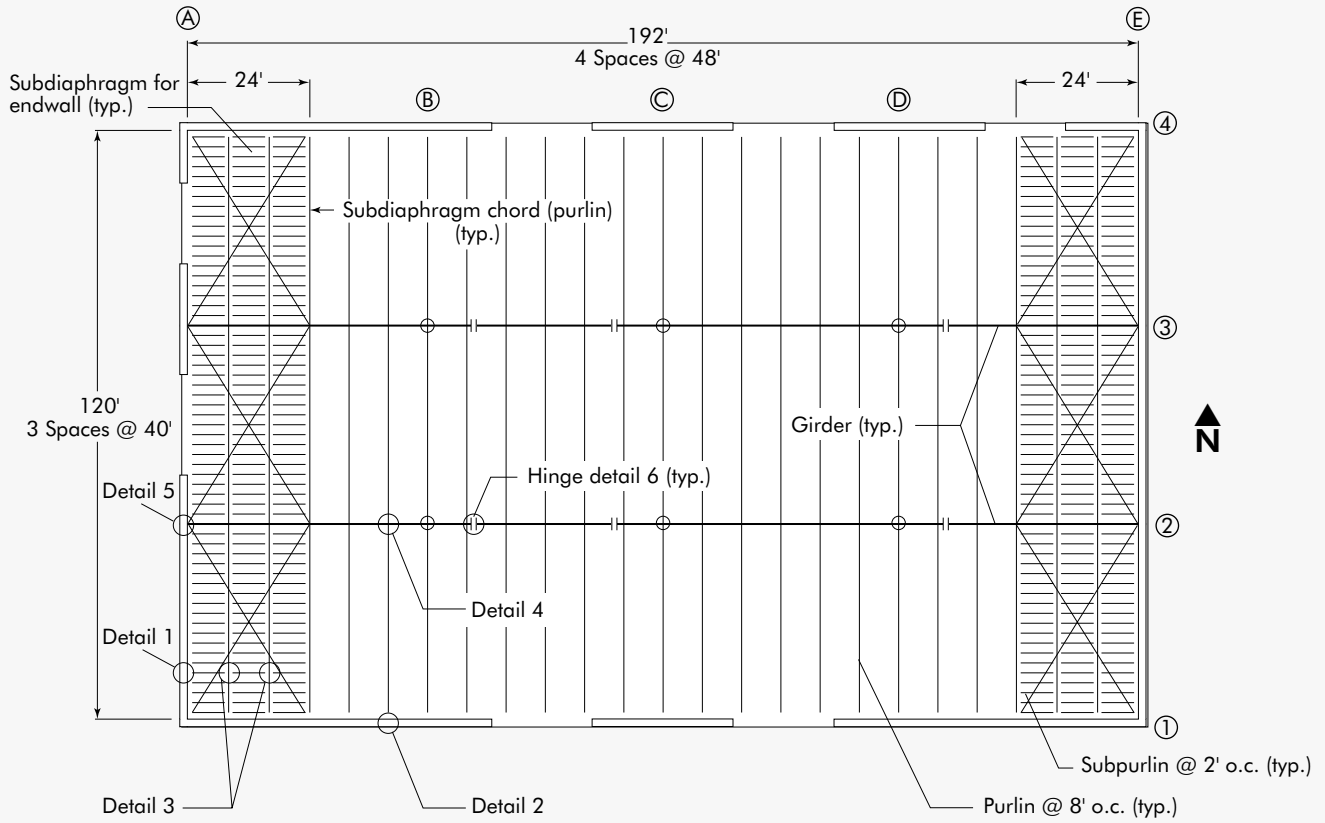

FIGURE 3

PANELIZED ROOF CONTINUITY TIES (EAST-WEST LOCATIONS SHOWN)

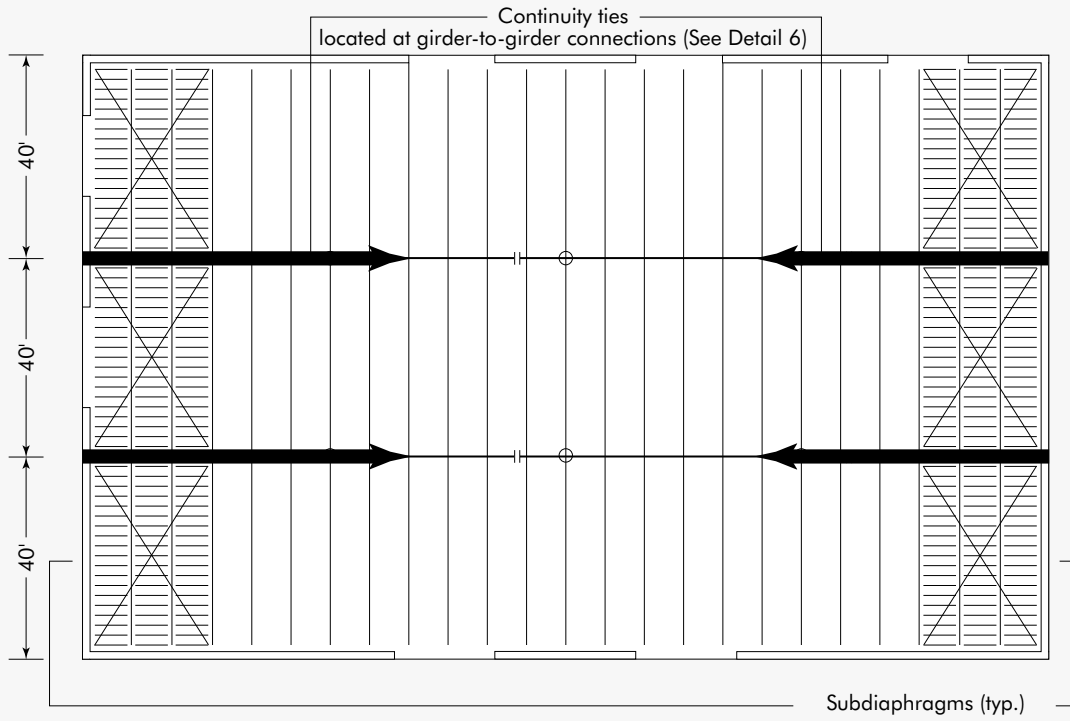
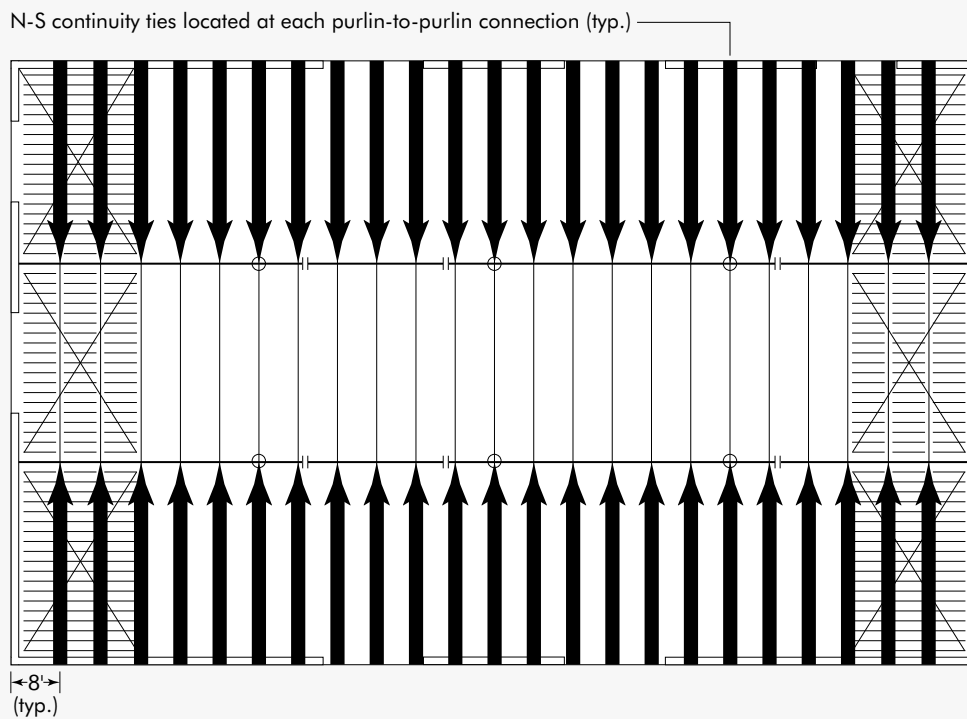

FIGURE 4

PANELIZED ROOF CONTINUITY TIES (NORTH-SOUTH LOCATIONS SHOWN)



DETAIL 1

WALL-TO-SUBPURLIN CONNECTION DETAILS

(Subpurlins spaced at 4' on center typically require a tension/compression connection of about 5,000 lb at the wall.)

SECTION

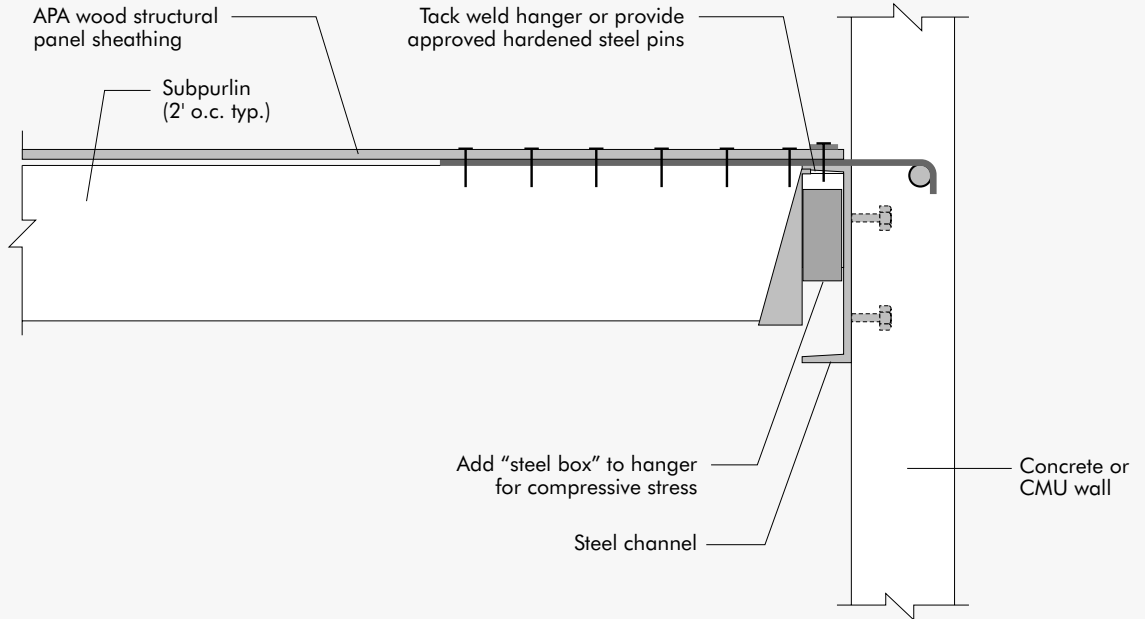

PLAN

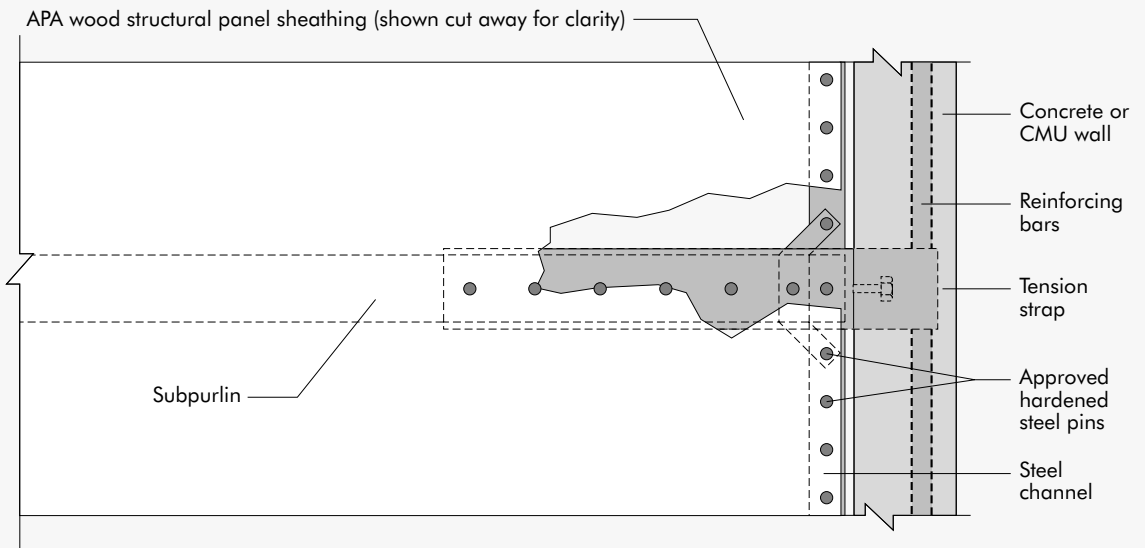

DETAIL 2A

WALL-TO-PURLIN CONNECTION DETAILS

(Purlins spaced at 8' on center typically require a tension/compression connection of about 10,000 lb at the wall.)

SECTION

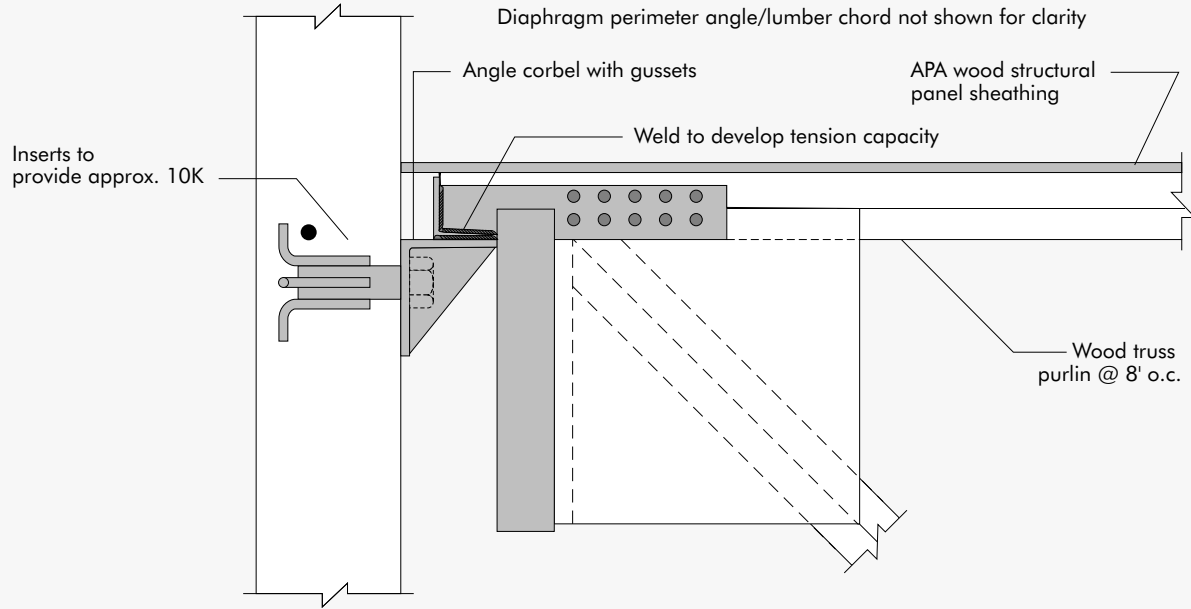

PLAN

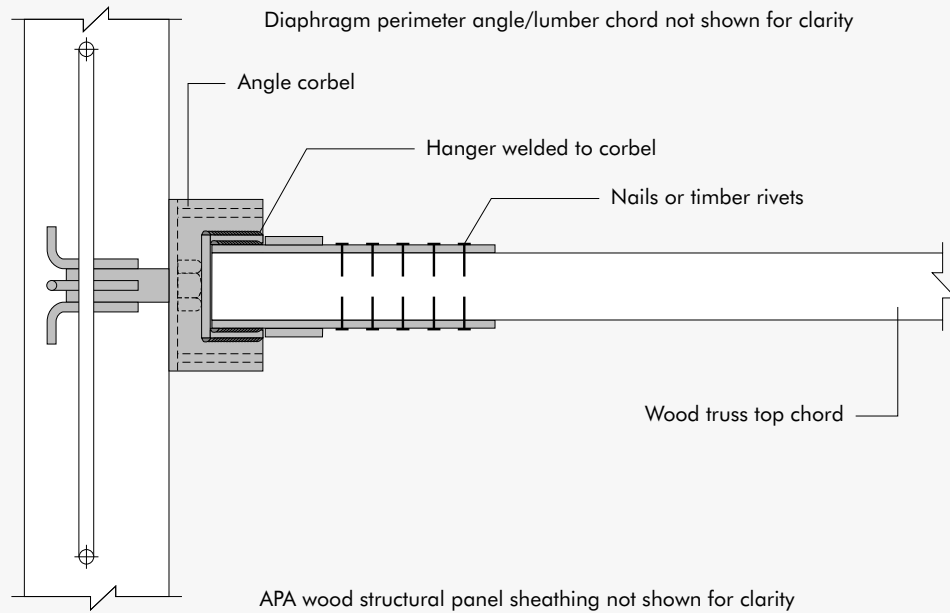

DETAIL 2B

WALL-TO-PURLIN CONNECTION DETAILS

(Purlins spaced at 8' on center typically require a tension/compression connection of about 10,000 lb at the wall.)

SECTION

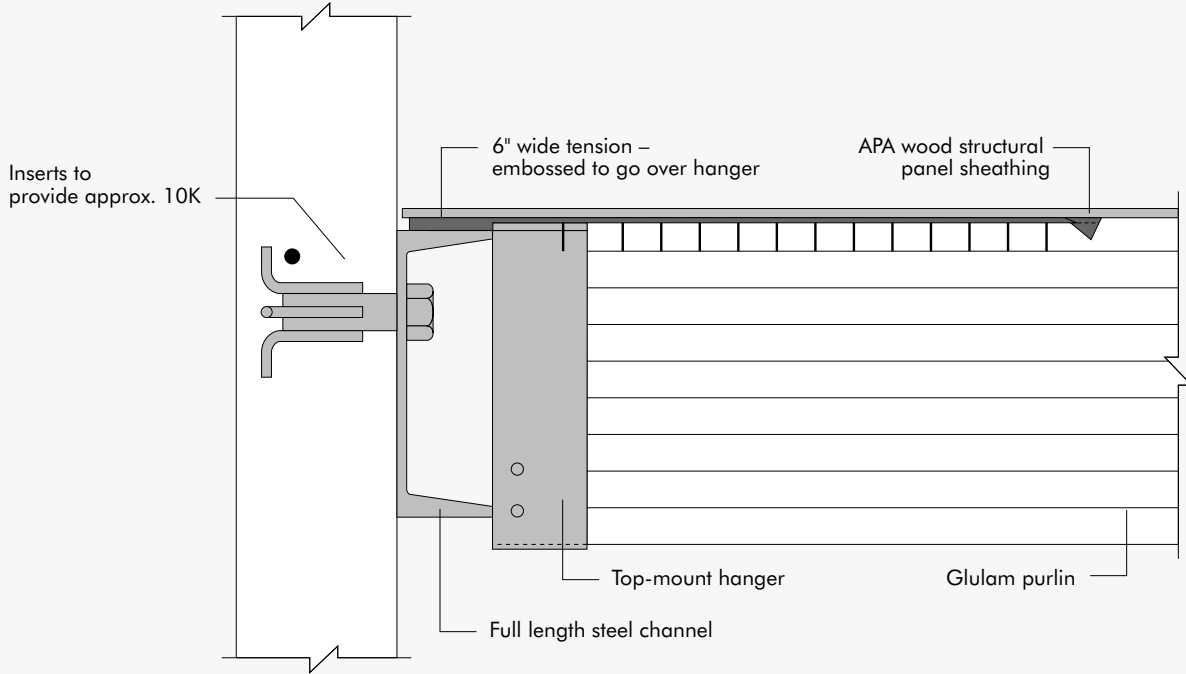

PLAN

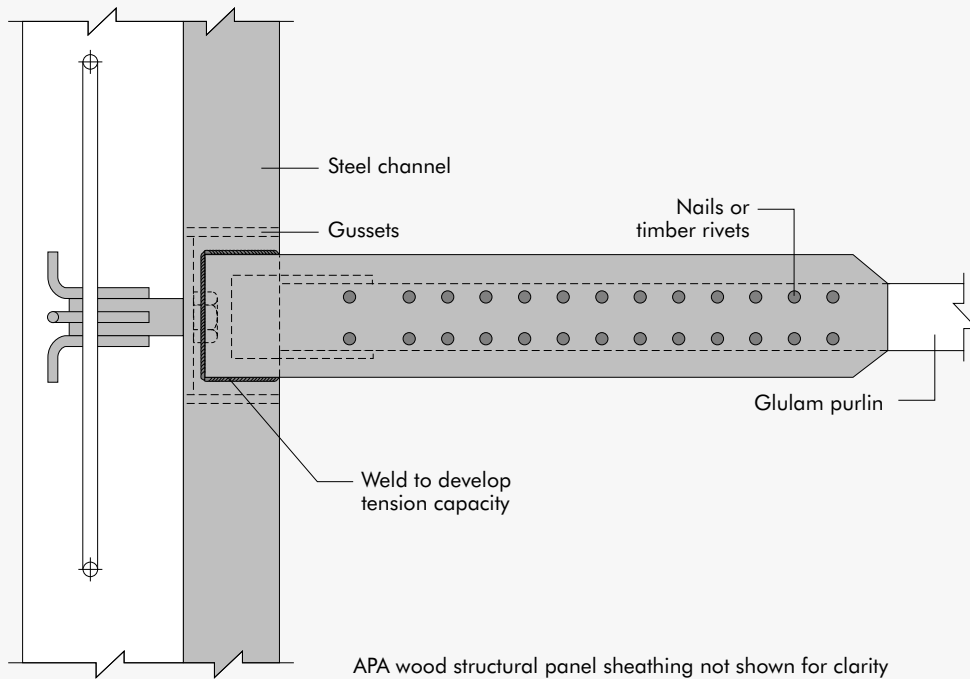

DETAIL 3

SUBPURLIN-TO-SUBPURLIN CONTINUITY-TIE CONNECTION DETAIL AT PURLINS

(Subpurlins spaced at 4' on center typically require a tension/compression connection of about 5,000 lb between subpurlins.)

SECTION

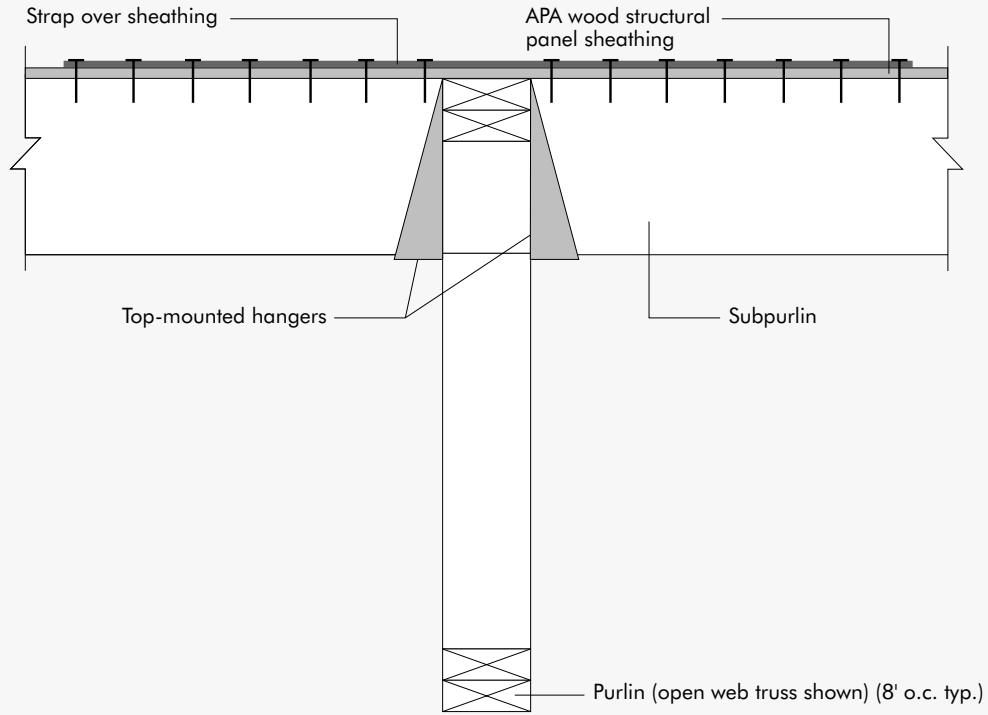

PLAN

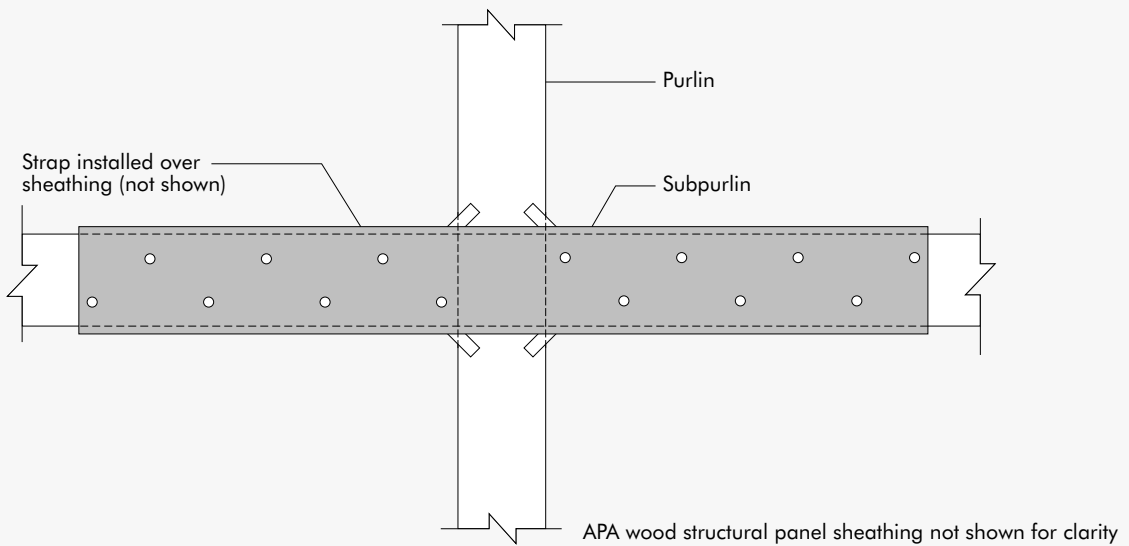

DETAIL 4A

PURLIN-TO-PURLIN CONTINUITY-TIE CONNECTION DETAIL AT GIRDER

(Purlins spaced at 8' on center typically require a tension/compression connection of about 10,000 lb between purlins.)

SECTION

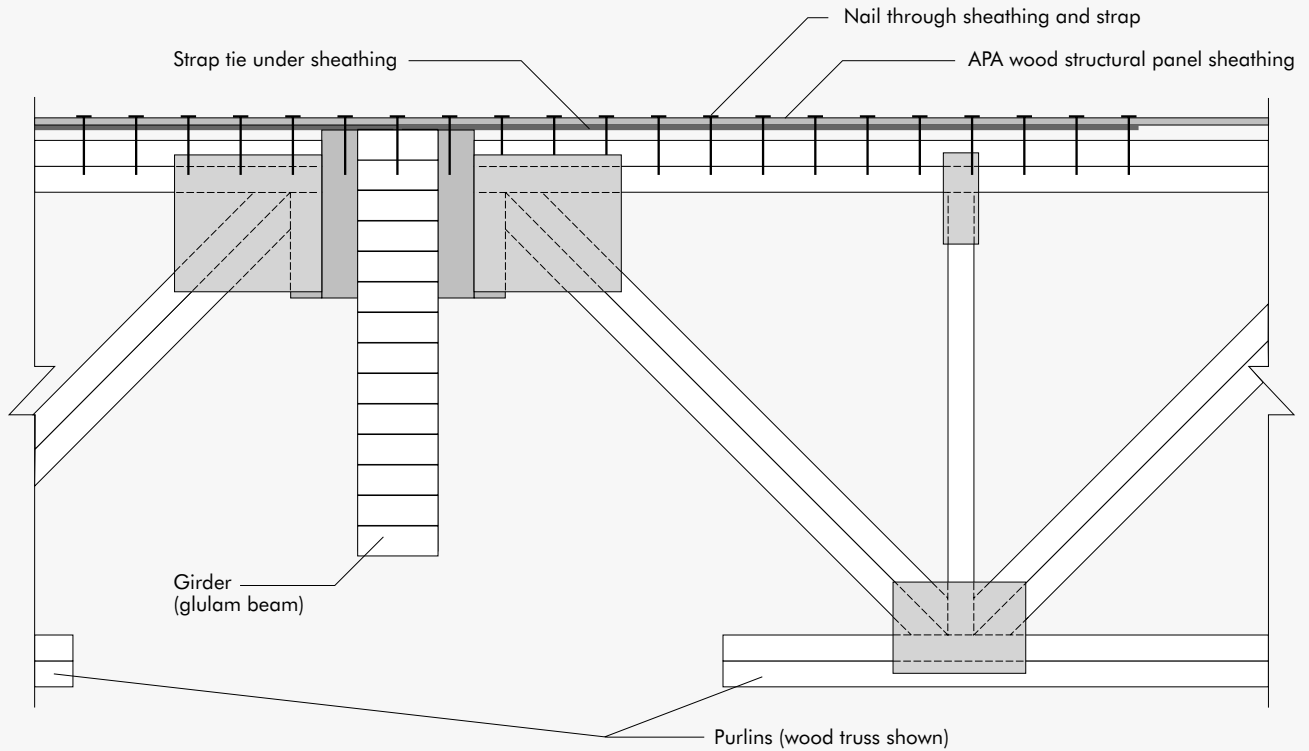

PLAN

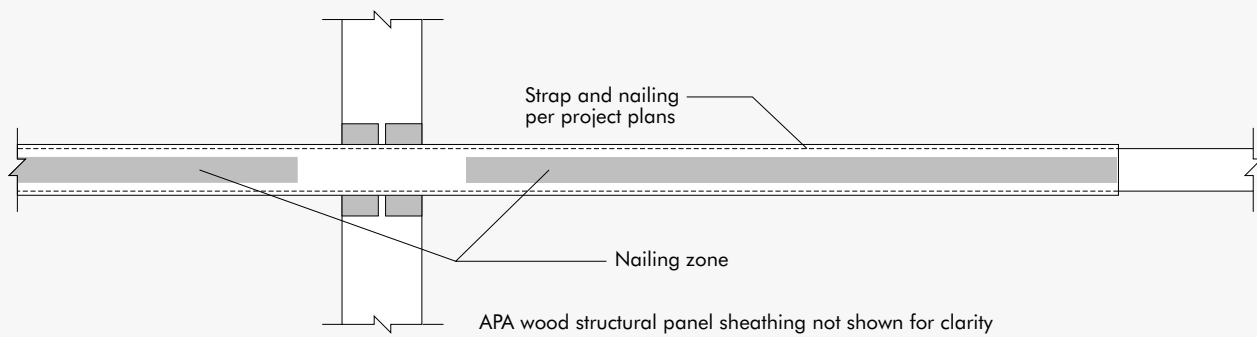

DETAIL 4B

ALTERNATE PURLIN-TO-PURLIN CONTINUITY-TIE CONNECTION DETAIL AT GIRDER

(Purlins spaced at 8' on center typically require a tension/compression connection of about 10,000 lb between purlins.)

SECTION

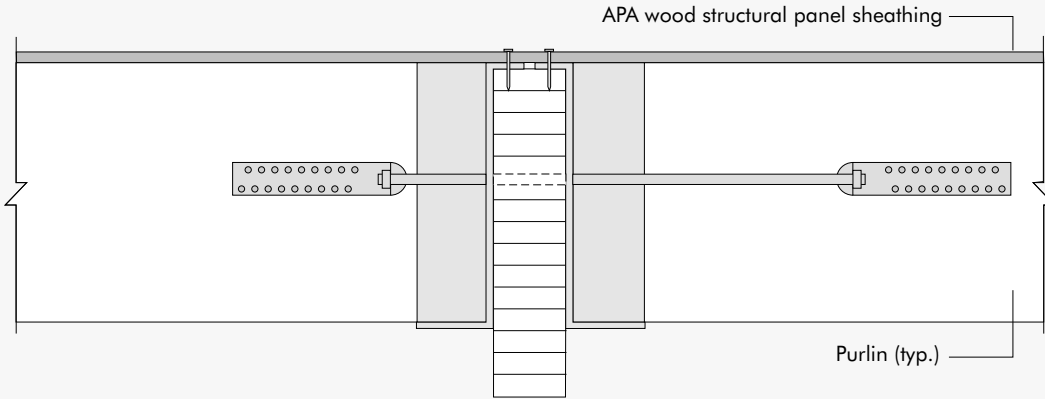

PLAN

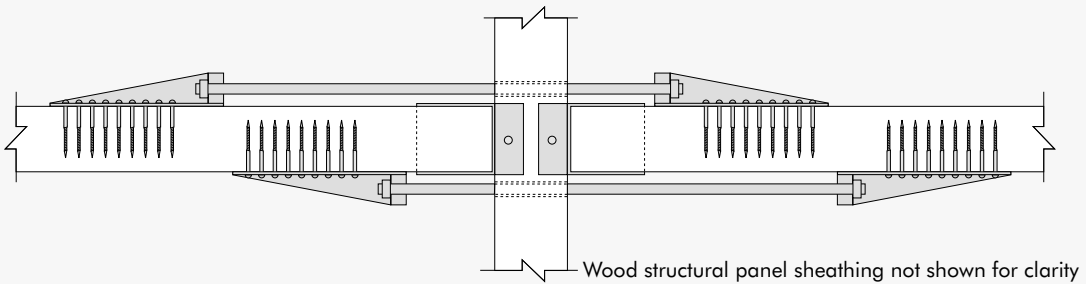

DETAIL 5A

WALL-TO-GIRDER CONNECTION DETAILS

(At wall, lateral load on girder equal to load on subpurlin – approximately 5,000 lb tension and compression. Uplift load at girder ends from wind forces on roof deck is very high at this location and may control bolted connection detail.)

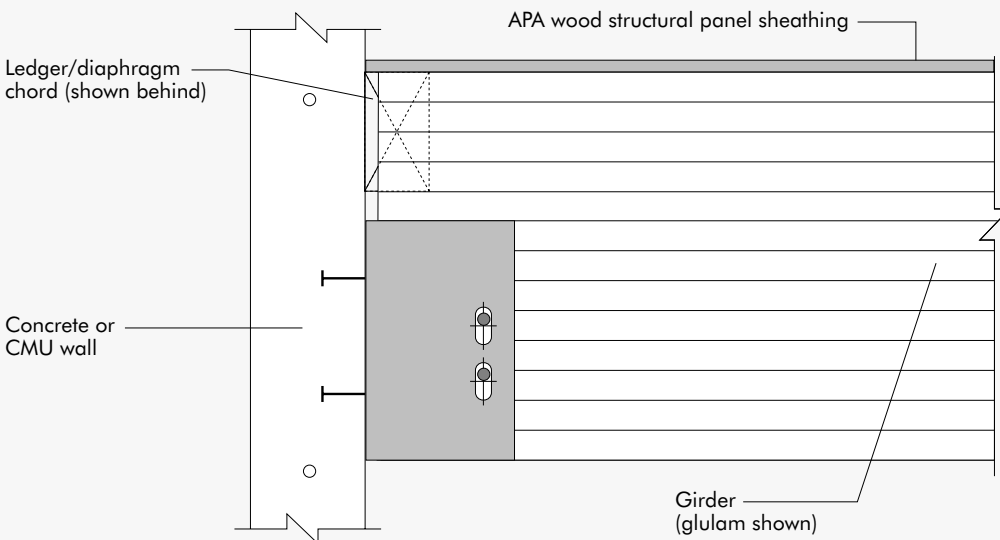

DETAIL 5B

WALL-TO-GIRDER CONNECTION DETAILS

(At wall, lateral load on girder equal to load on subpurlin – greater than 5,000 lb tension and compression. Uplift load from wind forces on girder is very high at this location and may control bolted connection detail.)

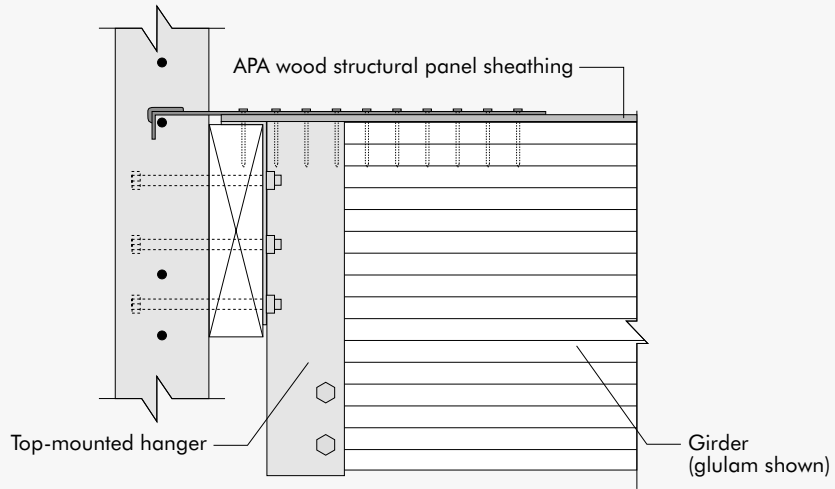

DETAIL 6

GIRDER-TO-GIRDER CONNECTION DETAILS

(At girder-to-girder connection, lateral load can be as high as 50 to 60 thousand pounds, depending on subdiaphragm design. Uplift load from wind forces at connection should be checked.)

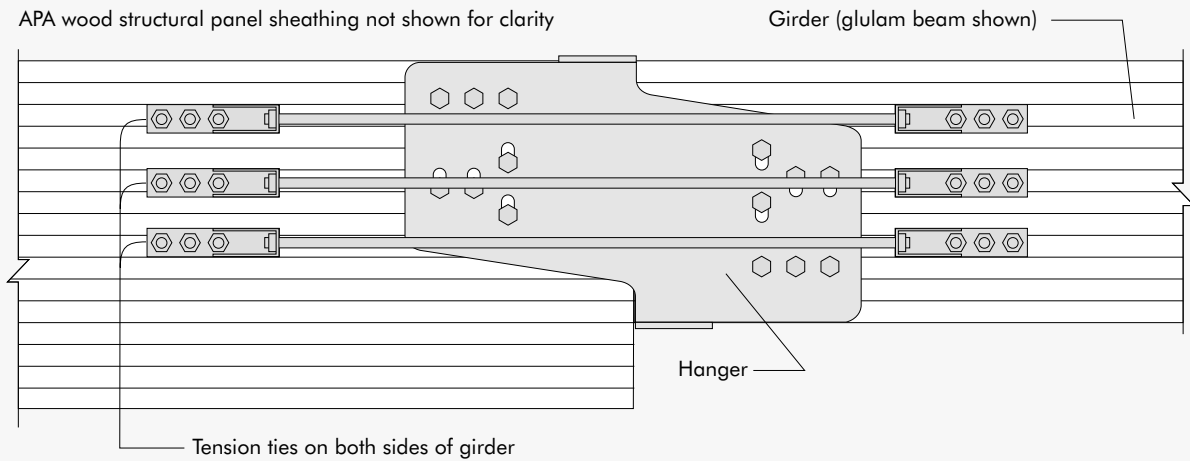

APPENDIX A

SUBDIAPHRAGMS

The subdiaphragm (also known as the mini-diaphragm) concept has been recognized by the building codes and extensively used to provide a method of meeting the wall attachment and continuous cross-tie code requirements, while minimizing the number and length of ties required to achieve continuity between chords.

What is a subdiaphragm? The 1997 Uniform Building Code (UBC) defines it as follows:

“SUBDIAPHRAGM is a portion of a larger wood diaphragm designed to anchor and transfer local forces to primary diaphragm struts and the main diaphragm.”

The subdiaphragm concept is used to concentrate and transfer local wall attachment forces to main structural members supporting the roof vertical loads. These main structural members are usually large enough to accommodate the concentrated lateral loads and provide sufficient “room” to make the requisite connections. The members generally run the full length and width of the building, using few connections, and can often economically provide the code-required cross-ties.

In general, the bigger the roof, the greater the savings made by using subdiaphragms.

Discussion

Each subdiaphragm must meet all of the diaphragm requirements provided in the controlling building code. Each subdiaphragm must have chords, continuous tension ties, and sufficient sheathing thickness and attachment to transfer the shear stresses generated within the diaphragm sheathing by the subdiaphragm. In addition, the 1997 UBC contains aspect ratio requirements specific to subdiaphragms.

Note that the subdiaphragm is actually the same structure as the roof diaphragm, utilizing the same roof sheathing to transfer shear stresses. However, the sheathing nailing and thickness requirements of the roof diaphragm may not be sufficient for subdiaphragm requirements. In that case, the subdiaphragm requirements would control and dictate the roof sheathing and fastening requirements in the subdiaphragm locations. Similarly, the roof diaphragm requirements may be more stringent than those for the subdiaphragm.

Design Example:

Consider the portion of the roof framing plan shown in Figure A1 below. This size of structure and roof framing design is

very typical for this type of structure. Buildings larger than the one illustrated are often framed in the same size modules, resulting in similar loads at each connection point. (Tables are provided in Appendix B for seismic zones 2A, 2B, 3, and 4 which provide more precise examples of the magnitude of loads that can be expected at the various connection locations.)

For this design example, the structure is located in Seismic Zone 4. The building has an importance factor of 1.0 and is located greater than 10 km from a known seismic source. For this example, assume that seismic forces govern the design. A single element of the subdiaphragm system for the roof in the East-West direction will be designed.

Subdiaphragm Selection

One of the major limitations that applies to the selection of the subdiaphragm is the code-specified subdiaphragm length-to-width ratio. Other than that, there are two requirements that most often dictate the selection of the subdiaphragm boundaries:

1. The subdiaphragm must have continuous chords at the edges perpendicular to the load.
2. A load path for the wall attachment forces must be maintained between the subdiaphragm chords.

FIGURE A1

SUBDIAPHRAGM DESIGN EXAMPLE

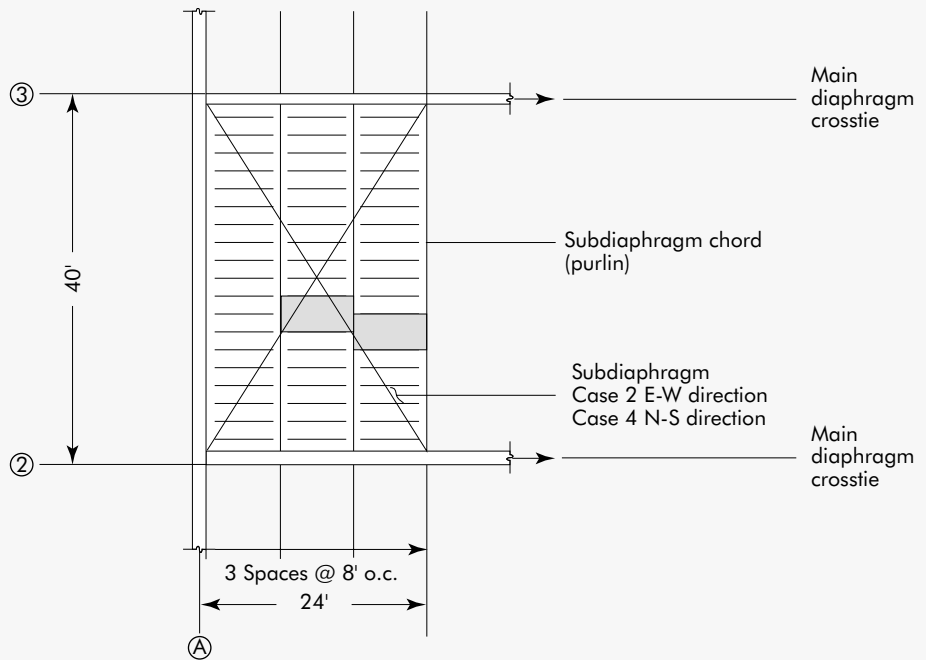
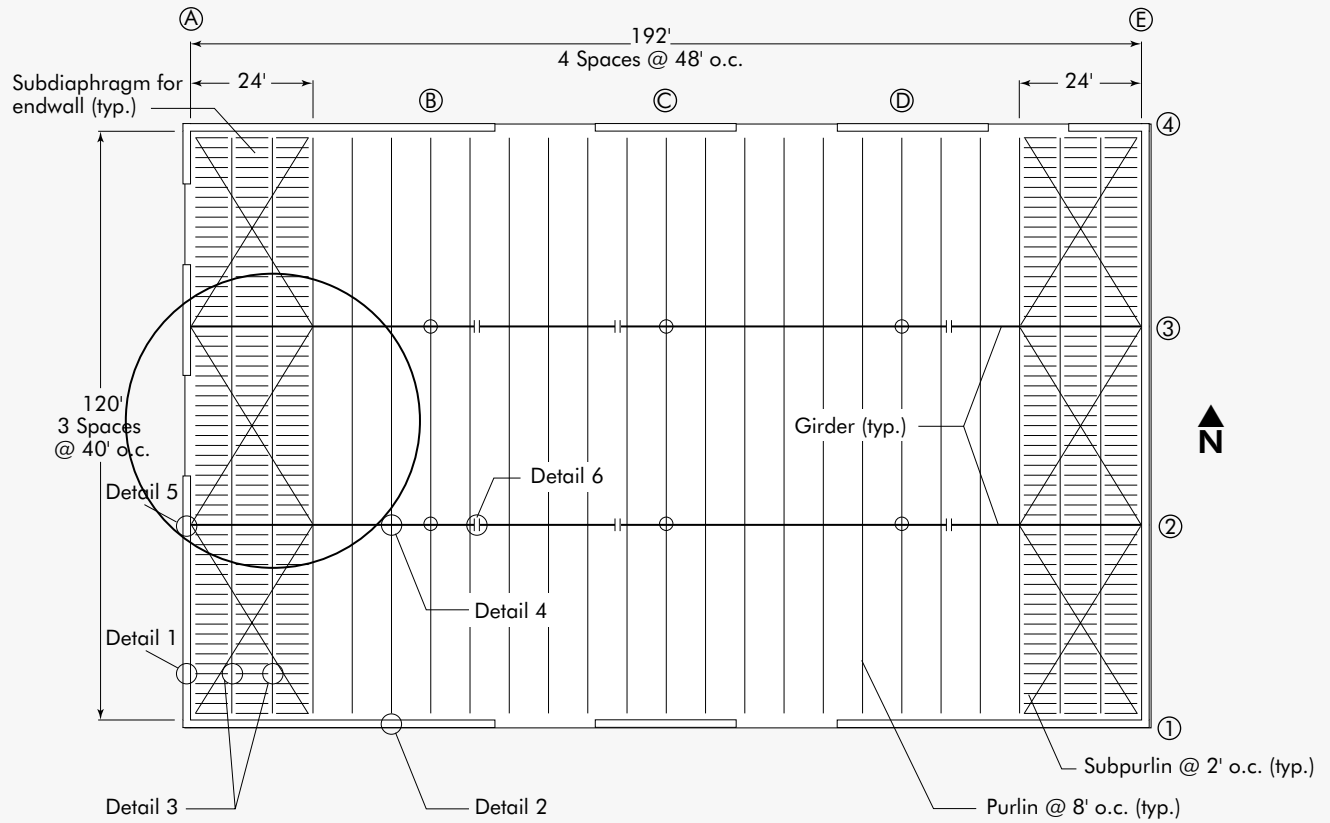

3. To maximize efficiency, a subdiaphragm depth is selected such that the main diaphragm nail schedule and sheathing thickness govern the design.

Most of the time, it is more efficient to use the existing continuous framing members as the subdiaphragm chords and main diaphragm crossies. In the North-South direction the existing purlins at 8 feet on center run between the main roof diaphragm chords and can efficiently transfer the wall attachment forces.

Because the building is only three bays deep and direct transfer of tension forces between purlins occurs at only 2 locations (along column lines 2 and 3), use of direct crossies is probably the most efficient solution although subdiaphragms could be used.

In the East-West direction, the building is deep enough and the roof framing is oriented such that the use of subdiaphragms will provide an efficient and economical solution. The alternative is to tie the main roof diaphragm chords together by use of the subpurlins. From Figure A1 it can be seen that **each** line of subpurlins would have to be spliced 23 times if the subdiaphragm was not used. The use of subdiaphragms can eliminate many hundreds of these connections.

As the subdiaphragm utilizes the same sheathing and framing elements as the roof diaphragm, the first step of the design example will be the design of the main roof diaphragm.

Diaphragm Design – North-South Direction

■ Base shear – Assume **1433** plf on an allowable stress design (ASD) basis. In practice, base shear calculations are conducted in accordance with 1997 Uniform Building Code (UBC) Chapter 16 and divided by 1.4 to convert from strength design to ASD basis. The North-South direction was selected because it would provide the maximum and therefore controlling diaphragm shear.

$$\text{Maximum Diaphragm Shear}_{N-S} - (1433 \times 192) / 2 \times 120 = \mathbf{1146} \text{ plf}$$

From ICBO Evaluation Service, Inc. Report ER-1952 (Table 2), use a blocked diaphragm with 23/32-inch-thick wood structural panel sheathing with 3 rows of 10d nails at 4" on center at diaphragm perimeter and at all other panel edges – 4" nominal framing required. This yields a diaphragm capacity of **1400** plf for Case 4 shown.

$$\text{Maximum chord force} - (1433) \times (192)^2 / (8 \times 120) = \mathbf{55,000} \text{ lb}$$

■ Check main diaphragm length-to-width ratio – $192/120 = 1.6$, $1.6 < 4$ therefore OK.

(Note that since there are no subdiaphragms being used in this direction the regular diaphragm ratio of 4/1 is appropriate. (1997 UBC Table 23-11-G))

■ Wall anchorage force – Assume **1194** plf ASD basis. In practice, wall anchorage force calculations are conducted in accordance with 1997 UBC Chapter 16 and divided by 1.4 to convert from strength design to ASD basis.

■ Wall anchor design – Purlins are connected to the side walls at 8 ft on center. Since there are no other framing members at this location running North and South, the wall attachment must be made at each purlin attachment point. Because the distance between the wall anchorage locations exceeds 4 ft on center, the walls must be designed to transfer this load in bending between anchorage points. (1997 UBC, Section 1605.2.3.)

$$\text{Wall anchorage force} = 8 \times 1194 \times 0.85 = \mathbf{8120} \text{ lb per purlin anchor.}$$

(See Details 2A and 2B.)

The 0.85 factor is in accordance with UBC Section 1633.2.8.1, item 5. It was assumed that the purlin has a net thickness of at least 2-1/2 inches. The reduced force applies to the wood member. It is not appropriate for the design of the concrete anchor; the steel member should be checked in accordance with Section 1633.2.8.1, item 4. The design of the steel connector is beyond the scope of this publication. The connector manufacturer should be consulted for guidance.

■ Calculate purlin-to-purlin connection – Tension straps must be used to provide anchorage force continuity along every purlin from the south wall diaphragm chord to the north wall chord. (UBC Section 1633.2.9.4) This continuity tie will have a capacity equal to **8120** lb as given above. (See Details 4A and 4B.) See notes above for the implications of designing with the reduced force.

■ As before, the purlins in this direction will have to be checked for combined bending and axial stresses.

Subdiaphragm Design – East-West Direction

Assume a subdiaphragm extending between column line 2 and line 3, and from column line A extending out toward column line B for 24 ft. (See Figure A1)

■ Check length-to-width ratio of subdiaphragm: $40/24 = 1.66$
 $1.66 < 2.5$ therefore OK.
(1997 UBC Section 1633.2.9, item 4)

■ Wall anchor design – Subpurlins connect to walls at 2 ft on center. Use every other subpurlin to transfer the wall anchorage forces into the subdiaphragm. Thus the distance between the wall anchorage locations equals 4 ft (2 x 2 ft) and the walls do not have to be designed to transfer this load in bending between anchorage points. Wall anchorage force = $4 \times 1194 \times 0.85 = 4060$ lb per subpurlin anchor. (See Detail 1.) The subpurlins must be 3x members, per Section 1633.2.8.1, Item 5.

Continuous connections must be used to provide wall anchorage from the west wall inward 24 ft to the third purlin line. This purlin will be used as the subdiaphragm chord. As the subpurlins run from purlin to purlin, subpurlin tension straps are required at every other subpurlin at the first, second and third purlin lines only. Note that the code requirement to provide continuous crossties between diaphragm chords applies to subdiaphragms as well as the main structural diaphragm. (UBC Section 1633.2.9.4) The required capacity of these connections is the same as the subpurlin-to-wall anchor capacity – **4060 lb**. (See Detail 3.) These members also must be 3x wood.

■ Check on the transfer of wall anchorage force into subdiaphragm sheathing – The required anchorage force of **4780 lb** per anchor must be transferred into the roof sheathing over the depth of the subdiaphragm. This requires shear transfer capacity of $4780 / (24) = 200$ plf along the length of subdiaphragm. Assuming minimum nail frequency of 18 nails per foot (from *Diaphragm Design* above), shear transfer of 11 lb/nail must be accomplished. OK by inspection.

■ Calculate subdiaphragm shear – $(1194) \times (40) / (2 \times 24) = 995$ plf. **Main diaphragm shear controls (1400 > 995) so diaphragm sheathing will function as subdiaphragm sheathing.**

■ Calculate subdiaphragm chord force – $(1194) \times (40)^2 / (8 \times 24) = 9950$ lb. Since a purlin forms the subdiaphragm chord and is continuous for the full length of the subdiaphragm, no splices are necessary. This purlin, however, must be checked for combined bending (roof load) and axial (chord force) stresses.

■ Calculate East-West crosstie force at girder-to-girder connections along column lines 2 and 3 – $(1194) \times 40 \times 0.85 = 40,600$ lb. Tension ties must be used to provide **40,600 lb** tension continuity at girder splices occurring between column lines A and E. (UBC Section 1633.2.9.4) (See Detail 6.) In addition, the girder capacity must be checked for combined bending and axial stresses. See earlier discussion for the implications of designing with the reduced force.

■ Calculate East-West crosstie force at girder-to-wall connections along column lines 2 and 3 – At these locations the crosstie force in the girders is equal to that in the subpurlins used to provide wall-anchorage continuity running parallel to it (**4780 lb**). (See Details 5A and 5B.) Over the depth of the subdiaphragm, the anchorage force on the girder increases to that equal to the girder-to-girder capacity (**40,600 lb**) calculated above.

APPENDIX B

TYPICAL SEISMIC LOADS^{1,2} – SEISMIC ZONE 2A, 1997 UBC

Wall Height ³ (ft)	Wall Thickness (in.)	Tributary Wall Height ⁴ (ft)	Tributary Wall Weight (plf)	Seismic Design Force (plf)	Subpurlins ⁵ – 4 ft on center (lbf)	Purlins ⁶ – 8 ft on center (lbf)	Girder Splice ⁷ – 48 ft on center (kips)
20	5.5	14	963	275	1100	2200	13.2
	6	14	1050	300	1200	2400	14.4
25	7.25	16.5	1495	427	1709	3418	20.5
	8	16.5	1650	471	1886	3771	22.6
30	7.25	19	1722	492	1968	3936	23.6
	8	19	1900	543	2171	4343	26.1
	9.25	19	2197	628	2511	5021	30.1
35	8	21.5	2150	614	2457	4914	29.5
	9.25	21.5	2486	710	2841	5682	34.1
	10	21.5	2688	768	3071	6143	36.9
40	10	24	3000	857	3429	6857	41.1
	11.25	24	3375	964	3857	7714	46.3
	12	24	3600	1029	4114	8229	49.4
45	11.25	26.5	3727	1065	4259	8518	51.1
	12	26.5	3975	1136	4543	9086	54.5
50	12	29	4350	1243	4971	9943	59.7

1. This table is based on Section 1632.2, assuming Soil Profile Type SE (most conservative assumption), which results in $C_a = 0.3$ per Table 16-Q. The value for $a_p = 1.0$ and $R_p = 3.0$ per Section 1633.2.4.2 Item 4. Finally, $I_p = 1.0$ per Table 16-K and a flexible diaphragm. The Engineer of Record should confirm these assumptions are appropriate for the actual design. Section references refer to the 1997 UBC.

2. Seismic forces apply to the wood members, subdiaphragms, concrete connections and steel connectors.

3. Wall height is measured from top of roof sheathing to slab.

4. Assumes a 4-ft-high parapet.

5. See Details 1, 3, 5A, and 5B.

6. See Details 2A, and 4A, and 4B.

7. See Detail 6.

Example Calculations

Example calculations for Seismic Zone 2A (calculations for Seismic Zone 2B are exactly the same with the exception $C_a = 0.34$).

Assume: Wall Height = 30 feet, wall thickness 8 inches and density of walls = 150 pcf.

Tributary Wall Height (feet) = parapet height + half of wall height = 4 + 30/2 = 19 feet.

Tributary Wall Weight (plf) = Tributary wall height x wall width x wall density = 19 x 8/12 x 150 = 1900 plf.

Seismic Design Force (Equation 32-2):

$$F_p = \frac{a_p C_a I_p}{R_p} \left(1 + 3 \frac{h_x}{h_r} \right) W_p$$

$$F_p = \frac{(1.0)(0.30)(1.0)}{3.0} \left(1 + 3 \frac{30}{30} \right) W_p = 0.400 W_p$$

Check that results from Equation 32-2 fall within Equation 32-3, i.e., F_p shall not be less than $0.7C_aI_pW_p$ and need not be more than $4C_aI_pW_p$, resulting in $0.210 W_p$ and $1.2 W_p$, respectively, therefore Equation 32-2 controls.

$$F_p = 0.400 \times 1900 \text{ plf} = 760 \text{ plf (strength basis).}$$

The seismic forces calculated per the 1997 UBC are fundamentally strength based. To convert to Allowable Stress Design (ASD) basis, the strength level forces can be divided by a factor of 1.4.

$$F_{p(ASD)} = 760/1.4 = 543 \text{ plf (ASD basis)}$$

For subpurlin force spaced at 4 ft on center (purlin force and girder splice forces calculated similarly based on tributary area for the component):

$$543 \times 4 = 2171 \text{ lbf.}$$

Equation numbers used in this example calculation refer to the 1997 UBC.

TYPICAL SEISMIC LOADS^{1,2} – SEISMIC ZONE 2B, 1997 UBC

Wall Height ³ (ft)	Wall Thickness (in.)	Tributary Wall Height ⁴ (ft)	Tributary Wall Weight (plf)	Seismic Design Force (plf)	Subpurlins ⁵ – 4 ft on center (lbf)	Purlins ⁶ – 8 ft on center (lbf)	Girder Splice ⁷ – 48 ft on center (kips)
20	5.5	14	963	312	1247	2493	15.0
	6	14	1050	340	1360	2720	16.3
25	7.25	16.5	1495	484	1937	3874	23.2
	8	16.5	1650	534	2137	4274	25.6
30	7.25	19	1722	558	2230	4460	26.8
	8	19	1900	615	2461	4922	29.5
	9.25	19	2197	711	2845	5691	34.1
35	8	21.5	2150	696	2785	5570	33.4
	9.25	21.5	2486	805	3220	6440	38.6
	10	21.5	2688	870	3481	6962	41.8
40	10	24	3000	971	3886	7771	46.6
	11.25	24	3375	1093	4371	8743	52.5
	12	24	3600	1166	4663	9326	56.0
45	11.25	26.5	3727	1207	4827	9654	57.9
	12	26.5	3975	1287	5149	10297	61.8
50	12	29	4350	1409	5634	11269	67.6

1. This table is based on Section 1632.2, assuming Soil Profile Type SE (most conservative assumption), which results in $C_a = 0.34$ per Table 16-Q. The value for $a_p = 1.0$ and $R_p = 3.0$ per Section 1633.2.4.2 Item 4. Finally, $I_p = 1.0$ per Table 16-K and a flexible diaphragm. The Engineer of Record should confirm these assumptions are appropriate for the actual design. Section references refer to the 1997 UBC.

2. Seismic forces apply to the wood members, subdiaphragm, concrete connections and steel connectors.

3. Wall height is measured from top of roof sheathing to slab.

4. Assumes a 4-ft-high parapet.

5. See Details 1, 3, 5A, and 5B.

6. See Details 2A, and 4A, and 4B.

7. See Detail 6.

See Seismic Zone 2A text for example calculations.

TYPICAL SEISMIC LOADS^{1,2} – SEISMIC ZONE 3, 1997 UBC

Wall Height ⁴ (ft)	Wall Thickness (in.)	Tributary Wall Height ⁵ (ft)	Tributary Wall Weight (plf)	Seismic Design Force (plf)	Subpurlins ^{3,6} – 4 ft on center (lbf)	Purlins ^{3,7} – 8 ft on center (lbf)	Girder Splice ^{3,8} – 48 ft on center (kips)
20	5.5	14	963	495	1683	3366	20.2
	6	14	1050	540	1836	4320	22.0
25	7.25	16.5	1495	769	2615	6152	31.4
	8	16.5	1650	849	2885	6789	34.6
30	7.25	19	1722	886	3011	7084	36.1
	8	19	1900	977	3322	7817	39.9
	9.25	19	2197	1130	3841	9039	46.1
35	8	21.5	2150	1106	3759	8846	45.1
	9.25	21.5	2486	1278	4347	10228	52.2
	10	21.5	2688	1382	4699	11057	56.4
40	10	24	3000	1543	5246	12343	62.9
	11.25	24	3375	1736	5901	13886	70.8
	12	24	3600	1851	6295	14811	75.5
45	11.25	26.5	3727	1917	6516	15332	78.2
	12	26.5	3975	2044	6951	16354	83.4
50	12	29	4350	2237	7606	17897	91.3

1. This table is based on Section 1632.2, assuming Soil Profile Type SD (most conservative assumption), which results in $C_a = 0.36$ per Table 16-Q. The value for $a_p = 1.5$ and $R_p = 3.0$ per Section 1633.2.8.1 Item 1, $I_p = 1.0$ per Table 16-K and a flexible diaphragm. The Engineer of Record should confirm these assumptions are appropriate for the actual design. Section references refer to the 1997 UBC.
2. Seismic forces apply to the wood members, subdiaphragms, and concrete connectors. Where noted per footnote 3, they have been reduced by a factor of 0.85 (see footnote 3). The steel connector should be checked per 1633.2.8.1 Item 4. The steel design of the connectors is beyond the scope of this publication. The connector manufacturer should be consulted for guidance.

3. Seismic forces have reduced by 0.85 per Section 1633.2.8.1 Item 5 (wood framing must have a thickness of at least 2-1/2 inches). The reduced forces are not appropriate for the design of concrete anchors.
4. Wall height is measured from top of roof sheathing to slab.
5. Assumes a 4-ft-high parapet.
6. See Details 1, 3, 5A, and 5B.
7. See Details 2A, and 4A, and 4B.
8. See Detail 6.

See Seismic Zone 4 text for example calculations.

TYPICAL SEISMIC LOADS^{1,2} – SEISMIC ZONE 4, 1997 UBC

Wall Height ⁴ (ft)	Wall Thickness (in.)	Tributary Wall Height ⁵ (ft)	Tributary Wall Weight (plf)	Seismic Design Force (plf)	Subpurlins ^{3,6} – 4 ft on center (lbf)	Purlins ^{3,7} – 8 ft on center (lbf)	Girder Splice ^{3,8} – 48 ft on center (kips)
20	5.5	14	963	605	2057	4114	24.7
	6	14	1050	660	2244	4488	26.9
25	7.25	16.5	1495	940	3196	6391	38.3
	8	16.5	1650	1037	3526	7053	42.3
30	7.25	19	1722	1082	3680	7360	44.2
	8	19	1900	1194	4061	8121	48.7
	9.25	19	2197	1381	4695	9390	56.3
35	8	21.5	2150	1351	4595	9190	55.1
	9.25	21.5	2486	1563	5313	10626	63.8
	10	21.5	2688	1689	5744	11487	68.9
40	10	24	3000	1886	6411	12823	76.9
	11.25	24	3375	2121	7213	14426	86.6
	12	24	3600	2263	7694	15387	92.3
45	11.25	26.5	3727	2342	7964	15928	95.6
	12	26.5	3975	2499	8495	16990	101.9
50	12	29	4350	2734	9297	18593	111.6

1. This table is based on Section 1632.2, assuming Soil Profile Type S_D (most conservative assumption), which results in C_a = 0.44N_a per Table 16-Q. The near source factor, N_a was assumed to be 1.0 per Table 16-S. The value for a_p = 1.5 and R_p = 3.0 per Section 1633.2.8.1 Item 1, I_p = 1.0 per Table 16-K and a flexible diaphragm. The Engineer of Record should confirm these assumptions are appropriate for the actual design. Section references refer to the 1997 UBC.

2. Seismic forces apply to the wood members, subdiaphragms, and concrete connectors. Where noted per footnote 3, they have been reduced by a factor of 0.85 (see footnote 3). The steel connector should be checked per 1633.2.8.1 Item 4. The steel design of the connectors is beyond the scope of this publication. The connector manufacturer should be consulted for guidance.

3. Seismic forces have reduced by 0.85 per Section 1633.2.8.1 Item 5 (wood framing must have a thickness of at least 2-1/2 inches). The reduced forces are not appropriate for the design of concrete anchors.

4. Wall height is measured from top of roof sheathing to slab.

5. Assumes a 4-ft-high parapet.

6. See Details 1, 3, 5A, and 5B.

7. See Details 2A, and 4A, and 4B.

8. See Detail 6.

Example Calculations

Example calculations for Seismic Zone 4 (Calculations for Seismic Zone 3 are similar except C_a = 0.36).

Assume: Wall Height = 30 feet, wall thickness 8 inches and density of walls = 150 pcf.

Tributary Wall Height (feet) = parapet height + half of wall height = 4 + 30/2 = 19 feet.

Tributary Wall Weight (plf) = Tributary wall height x wall width x wall density = 19 x 8/12 x 150 = 1900 plf.

Seismic Design Force (Equation 32-2):

$$F_p = \frac{a_p C_a I_p}{R_p} \left(1 + 3 \frac{h_x}{h_r} \right) W_p$$

$$F_p = \frac{(1.5)[(0.44)(1.0)](1.0)}{3.0} \left(1 + 3 \frac{30}{30} \right) W_p = 0.880 W_p$$

Check that results from Equation 32-2 fall within Equation 32-3, i.e., F_p shall not be less than $0.7C_aI_pW_p$ and need not be more than $4C_aI_pW_p$, resulting in $0.308 W_p$ and $1.760 W_p$, respectively, therefore Equation 32-2 controls.

$$F_p = 0.880 \times 1900 \text{ plf} = 1672 \text{ plf (strength basis).}$$

The seismic forces calculated per the 1997 UBC are fundamentally strength based. To convert to Allowable Stress Design (ASD) basis, the strength level forces can be divided by a factor of 1.4.

$$F_{p(ASD)} = 1672/1.4 = 1194 \text{ plf (ASD basis)}$$

For subpurlin force spaced at 4 ft on center (purlin force and girder splice forces calculated similarly based on tributary area for the component):

$$1194 \times 4 \times 0.85 = 4061.$$

Since subpurlins, purlins and girders are required to be 3x material or wider, it is permissible to reduce the seismic forces by a factor of 0.85 per Section 1633.2.8.1 Item 5, which requires the wood elements to have a minimum actual net thickness of 2-1/2 inches.

It is important to note that the reduced F_p applies for sizing the wood member, and for the fastener-to-wood portion of the connection design. The 0.85 factor is not appropriate for subdiaphragm, concrete or steel connector design. In fact, the steel portion of the connection design should be increased by an additional factor of 1.4 (not used in conjunction with the 0.85 factor) per Section 1633.2.8.1 Item 4. The steel analysis is beyond the scope of this document, the Engineer of Record should consult the fastener manufacturer.

For girder splice calculations spaced at 48 ft on center

$$1194 \times 48 \times 0.85 = 48.7 \text{ kips.}$$

Section references and equation numbers for these example calculations refer to the 1997 UBC.

We have field representatives in many major U.S. cities and in Canada who can help answer questions involving APA trademarked products. For additional assistance in specifying engineered wood products, contact us:

**APA – THE ENGINEERED
WOOD ASSOCIATION
HEADQUARTERS**

7011 So. 19th St.
Tacoma, Washington 98466
(253) 565-6600 • Fax: (253) 565-7265



www.apawood.org

PRODUCT SUPPORT HELP DESK

(253) 620-7400
E-mail Address: help@apawood.org

The product use recommendations in this publication are based on APA – The Engineered Wood Association's continuing programs of laboratory testing, product research, and comprehensive field experience. However, because the Association has no control over quality of workmanship or the conditions under which engineered wood products are used, it cannot accept responsibility for product performance or designs as actually constructed. Because engineered wood product performance requirements vary geographically, consult your local architect, engineer or design professional to assure compliance with code, construction, and performance requirements.

Form No. Z350A
Revised February 2004/0200

